

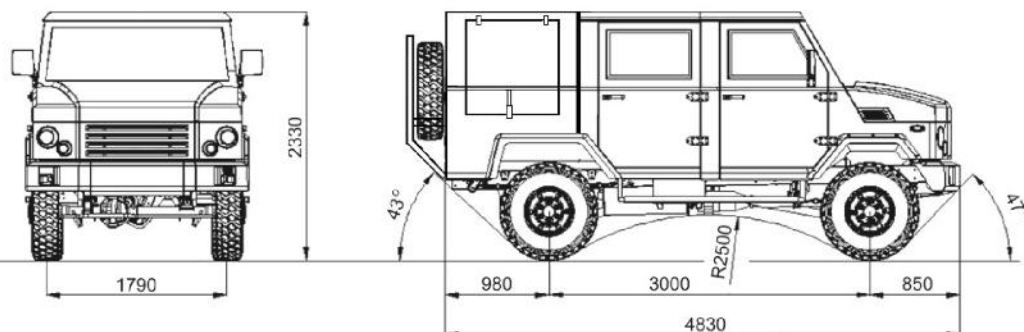

**ZASTAVA
KAMIONI**



NOVO TERENSKO VOZILO 40.13 H PRODUŽENA KABINA (4x4)



NOVO TERENSKO VOZILO 40.13 H PRODUŽENA KABINA (4x4)

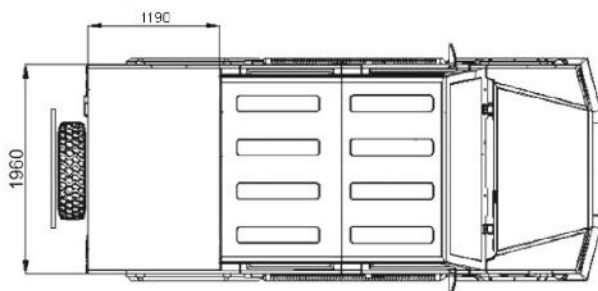

OSNO RASTOJANJE (mm)
WHEEL BASE (mm) 3000 (mm)

DUŽINA VOZILA (mm)
VEHICLE LENGTH (mm) 4830 (mm)

ŠIRINA VOZILA (mm)
VEHICLE WIDTH (mm) 2100 (mm)

DUŽINA TOVARNOG SANDUKA
LENGHT / CARGO CRATE 1190 (mm)

ŠIRINA TOVARNOG SANDUKA
WIDTH / CARGO CRATE 1960 (mm)

VISINA TOVARNOG SANDUKA
HEIGHT / CARGO CRATE 400 (mm)

TIP I VRSTA MOTORA ENGINE TYPE	EURO 3 Cummins ISF 2.8	- Dizel, četiri takta sa direktnim ubrizgavanjem goriva, (COMMON RAIL) - Diesel, four strokes with direct fuel injection, (COMMON RAIL)
RADNA ZAPREMINA DISPLACEMENT	2800 (cm³)	
Maksimalna snaga pri 3200 o/min. Maximum power at 3200 RPM	96 kW / 130 KS (HP)	
Maksimalni obrtni moment pri 1600 o/min. Maximum torque at 1600 RPM	310 Nm	
COOLING TYPE VRSTA HLADENJA	Vodeno Water	
SPOJNICA CLUTCH	Suva jednolamelasta 12" (310mm) Dry with a single disc 12" (310mm)	
MENJAČ GEARBOX	5S 400 ZF	Mechanical with 5 synchronized gears for forward movement and reverse Mehanički sa 5 sinhronizovanih stepena prenosa napred i hodom nazad
KOČNICA		Radna kočnica - hidraulička sa pedalom deluje na sva četiri točka sa depresionim servopojajivačem i nezavisnom cirkulacijom za prednje i zadnje točkove Napred: disk; Nazad: doboš Parkirna kočnica - mehanička, ručna deluje na zadnje točkove.
BREAKS	ABS + EBD + ABD	Working brakes - hydraulic pedal works with four wheel drive with depression servo-amplifier and independent circulation in front and rear wheels disk in front, drums in the rear Parking brake - mechanical, hand operates the rear wheels.
UPRAVLJAČ STEERING WHEEL		Hidraulički sa servo dejstvom Hydraulic with servo action
KOMANDE BLOKADE		- elektro komanda blokade razdelnika pogona - elektro komanda diferencijala u prednjem mostu - elektro komanda diferencijala u zadnjem mostu
BLOKADE COMMANDS		- electric blockade command separator drive - electric controls in the front differential bridge - electric controls in the rear differential bridge
PREDNJI MOST FRONT AXLE		Sa prostom redukcijom i električnom blokadom diferencijala. Prenosni odnos u diferencijalu 5,22 With a simple reduction and the electric differential blockade. Ratio of 5.22 differential
ZADNJI MOST REAR AXLE		Sa prostom redukcijom i električnom blokadom diferencijala. Prenosni odnos u diferencijalu 5,22 With a simple reduction and the electric differential blockade. Ratio of 5.22 differential
RAZVODNIK POGONA DISTRIBUTOR DRIVE		Mehanički, dvostepeni sa blokadom diferencijala, stalni pogon 4x4 Prenosni odnos: visoki prenos direktni 1,051 ; niski prenos - redukovani 3,937 Mechanical, two stage, with differential lock, constant drive 4x4, Ratio: high direct transfer: 1,051 ; Llow transfer reduced: 3,937
PNEUMATICI TIRES		255/100 R16
DOZVOLJENA UKUPNA MASA GVW		4500 (kg)
KORISNA NOSIVOST PAYLOAD		1500 (kg)
Max. dozvoljeno opterećenje na prednjoj osovini Max. permissible load on front axle		2000 (kg)
Max. dozvoljeno opterećenje na zadnjoj osovini Max. permissible load on rear axle		2800 (kg)